

Latches

Steel / Stainless Steel

SPECIFICATION

Types

- Type **SG**: Operation with star knob
- Type **DK**: Operation with triangular spindle (DK7)
- Type **VK7**: Operation with square spindle A/F7
- Type **VK8**: Operation with square spindle A/F8
- Type **VDE**: Operation with double bit

Version in Steel

- Lock housing / operating bolt
Zinc die casting, chrome plated
- Cam latch
Sheet Steel zinc plated, blue passivated
- Distance piece
Aluminium
- Star knobs VCT. (see page 244)
Plastic (Polypropylene PP)
black, matt

Version in Stainless Steel

- Stainless Steel AISI 303 **NI**
Cam latch AISI 304
- Stainless Steel-Star knob GN 5334 (see page 229)
AISI 304
- Protection class IP 65

INFORMATION

Latches GN 119 have a pulling-in range of 10 mm. Locking is achieved by turning the latch clockwise. The operating bolt of the stainless steel version is fitted with an O-ring for sealing.

TECHNICAL INFORMATION

- List of latch types (see page 1456)
- IP Protection classes (see page A23)
- Stainless Steel characteristics (see page A26)
- Plastic characteristics (see page A2)

ACCESSORY

- Socket keys GN 119.2 (see page 1530)
- Protective caps GN 120 (see page 1486)
- Opening handles GN 120.1 (see page 1487)



CONSTRUCTION AND ASSEMBLY INSTRUCTIONS

By turning the latch clockwise the stepped cam latch moves up behind the door frame and pulls the door in.

The large pulling-in range of the cam (10 mm) allows these locks to be used successfully on doors with sealing strips. When selecting clamping range 'A' the thickness of the door seal might have to be taken into consideration.

To fit the lock, the door will have to be provided with a hole as per sketch shown at a distance from the door frame to hole center of 23 mm.

The lock housing with the preassembled operating bolt is fitted into the hole from the front and held in position with the hexagon nut. The distance piece and the cam latch are then fitted at the rear and fixed with the hexagon nut.

In volume production, the **mounting borehole** in the door leaf is usually made by punching or laser machining.

For small series and steel sheets below 2 mm thickness, the sheet metal punches GN 123 (see page 1493) are the tool of choice.

The installation bore diameter can also be set by drilling / milling as shown in the outline drawings.

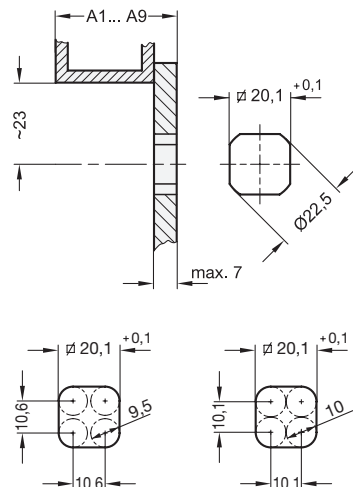

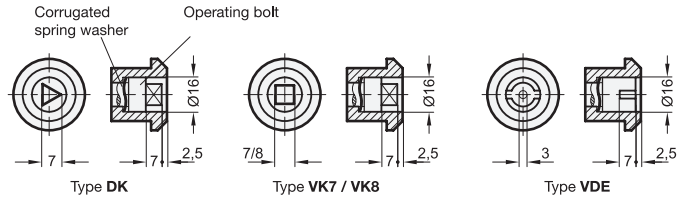
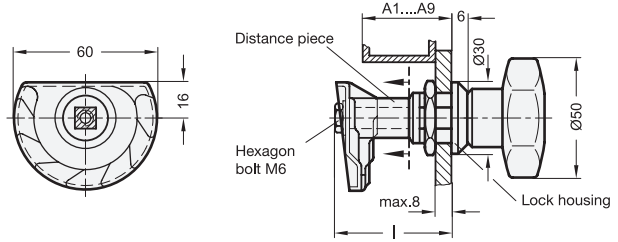

* Complete with type index of the latch

SG DK VK7 VK8 VDE

GN 119

Description	Clamping range A (Door + frame thickness)	Clamping range	⚖️
GN 119-*-A1	A 1 (l=35)	17 - 25	104
GN 119-*-A2	A 2 (l=40)	22 - 30	111
GN 119-*-A3	A 3 (l=45)	27 - 35	113
GN 119-*-A4	A 4 (l=50)	32 - 40	113
GN 119-*-A5	A 5 (l=55)	37 - 45	118
GN 119-*-A6	A 6 (l=60)	42 - 50	123
GN 119-*-A7	A 7 (l=65)	47 - 55	126
GN 119-*-A8	A 8 (l=70)	52 - 60	130
GN 119-*-A9	A 9 (l=75)	57 - 65	135

Weight type DK

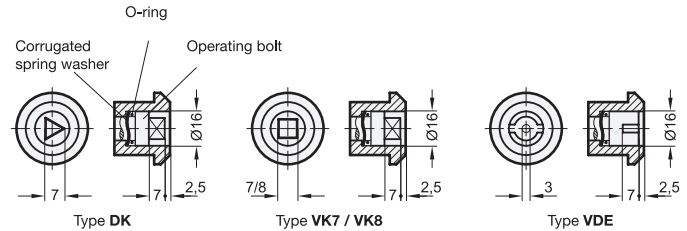
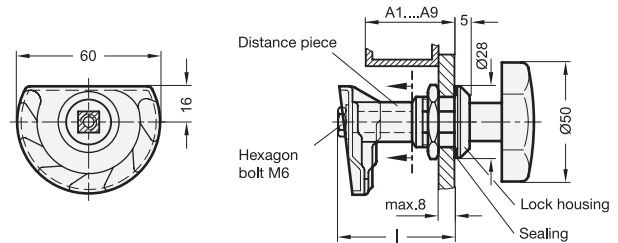

* Complete with type index of the latch

SG DK VK7 VK8 VDE

GN 119-NI

STAINLESS STEEL

Description	Clamping range A (Door + frame thickness)	Clamping range	⚖️
GN 119-*-A1-NI	A 1 (l=35)	17 - 25	100
GN 119-*-A2-NI	A 2 (l=40)	22 - 30	126
GN 119-*-A3-NI	A 3 (l=45)	27 - 35	140
GN 119-*-A4-NI	A 4 (l=50)	32 - 40	140
GN 119-*-A5-NI	A 5 (l=55)	37 - 45	160
GN 119-*-A6-NI	A 6 (l=60)	42 - 50	160
GN 119-*-A7-NI	A 7 (l=65)	47 - 55	170
GN 119-*-A8-NI	A 8 (l=70)	52 - 60	179
GN 119-*-A9-NI	A 9 (l=75)	57 - 65	204

Weight type DK

